

MAX-8

V2107.02



EP
Let's grow together

MAX-8

Excellent Performances & Reliability

CPCD15-18T8

T8 series 1.5-1.8t forklift

EP EQUIPMENT CO.,LTD
www.ep-ep.com



CPCD15/18T8

T8 series 1.5-1.8t forklift specification

General		EP	
1 Manufacture		CPCD15T8-SAQ 2	
2 Model		CPCD15T8-NB485BPG	
3 Power type		Diesel	
4 Rated capacity		1500	1800
5 Load center		500	500
6 Lift height		3000	3000
7 Free lift height		120	120
8 Fork size		920×100×40	
9 Mast tilt range		6/12	6/12
10 Fork overhang(wheel center to fork face)		420	420
11 Rear overhang		420	420
12 Length to face of fork		2270	2320
13 Overall width		1080	1080
14 Mast lowered height		1995	1995
15 Mast extended height		3960	3960
16 Overhead guard height		2070	2070
17 Turning radius(outside)		1995	2035
18 Min.tight angle stacking aisle width (Add load length and clearance)		2400	2440
19 Travel (No load)		14	14
20 Speed		460	460
21 Lowering (Full load)		450	450
22 Max. Drawbar Pull (Full load)		14300	14800
23 Max. Gradeability (Full load)		20	20
24 Tyres		6.50-10-10PR	
25		5.00-8-10PR	
26 Tread		920	920
27		920	920
28 Wheelbase		1430	1430
29 Ground clearance		110	110
30 Wheelbase center		140	140
31 Self weight		2700	2900
32		3570	3995
33 Weight		630	705
34 Distribution		1215	1305
35		1485	1595
36 Battery		12/60	12/60
37		S4Q2	S4Q2
38		NB485BPG	NB485BPG
39		Mitsubishi	Mitsubishi
40		XIN CHAI	XIN CHAI
41		32.9/2500	32.9/2500
42		131/1800	131/1800
43		4	4
44		88×103	88×103
45		2505	2505
46		50	50
47		OEM	OEM
48		Powershift	Powershift
Operating pressure		1/1	1/1
For attachments		15	15

1.Special lifting height available (2-stage mast :2.5m,2.7m,3.0m,3.3m,3.6m,3.7m,4m,4.3m,4.5m,5m. Full Free Duplex Mast 3.0m,3.3m,3.5m,3.6m. 3-stage mast : 4.3m,4.5m,4.8m,5m,5.5m,6m)
 2.Attachment available. 3. The specification in the table are for standard models only,For further information please contact us. 4.Specification are subject to change without notice.

1.5~1.8t T8 series mast: (pneumatic)

Type	Model	Max. fork height	Overall height				Free lift		Front Overhang		Tilt range		Capacity			
			Lowered	Extended		Without backrest	With backrest	1.5t	1.8t	FWD	BWD	Load capacity at 500 mm				
				Without backrest	With backrest							Single tire		Double tire		
												1.5t	1.8t	1.5t	1.8t	
Wide view mast	2W200	2000	1495	2585	2955	120	120	420	420	6	12	1500	1800	1500	1800	
	2W250	2500	1745	3085	3455	120	120	420	420	6	12	1500	1800	1500	1800	
	2W270	2700	1845	3285	3655	120	120	420	420	6	12	1500	1800	1500	1800	
	2W300	3000	1995	3585	3955	120	120	420	420	6	12	1500	1800	1500	1800	
	2W330	3300	2145	3885	4255	120	120	420	420	6	12	1500	1800	1500	1800	
	2W350	3500	2245	4085	4455	120	120	420	420	6	12	1500	1800	1500	1800	
	2W360	3600	2295	4185	4555	120	120	420	420	6	12	1500	1800	1500	1800	
	2W400	4000	2545	4585	4955	120	120	420	420	6	12	1400	1700	1500	1800	
	2W430	4300	2695	4885	5255	120	120	420	420	6	6	1300	1600	1400	1700	
2W450	4500	2795	5085	5455	120	120	420	420	6	6	1250	1500	1350	1600		
wide view full 2-stage mast	2F250	2500	1790	3105	3455	1045	765	420	420	6	12	1500	1800	1500	1800	
	2F270	2700	1890	3305	3655	1145	865	420	420	6	12	1500	1800	1500	1800	
	2F300	3000	2040	3605	3955	1345	1105	420	420	6	12	1500	1800	1500	1800	
	2F330	3300	2190	3905	4255	1495	1165	420	420	6	12	1500	1800	1500	1800	
	2F360	3600	2340	4205	4555	1645	1315	420	420	6	12	1500	1800	1500	1800	
	2F400	4000	2540	4605	4955	1815	1565	420	420	6	12	1400	1700	1500	1800	
wide view full 3-stage mast	3F430	4300	1965	5070	5255	1425	1080	440	440	6	6	1250	1500	1350	1600	
	3F450	4500	2045	5130	5465	1485	1140	440	440	6	6	1200	1400	1300	1500	
	3F480	4800	2160	5445	5755	1575	1230	440	440	6	6	1100	1300	1200	1400	
	3F500	5000	2210	5605	5955	1665	1320	440	440	6	6	1050	1200	1150	1300	
	3F550	5500	2375	6120	6455	1825	1480	440	440	3	6	/	/	950	1100	
	3F600	6000	2600	6695	6955	1975	1630	440	440	3	6	/	/	750	900	

Note:1. With sideshifter minus 150Kg, with integral sideshifter minus 100Kg.

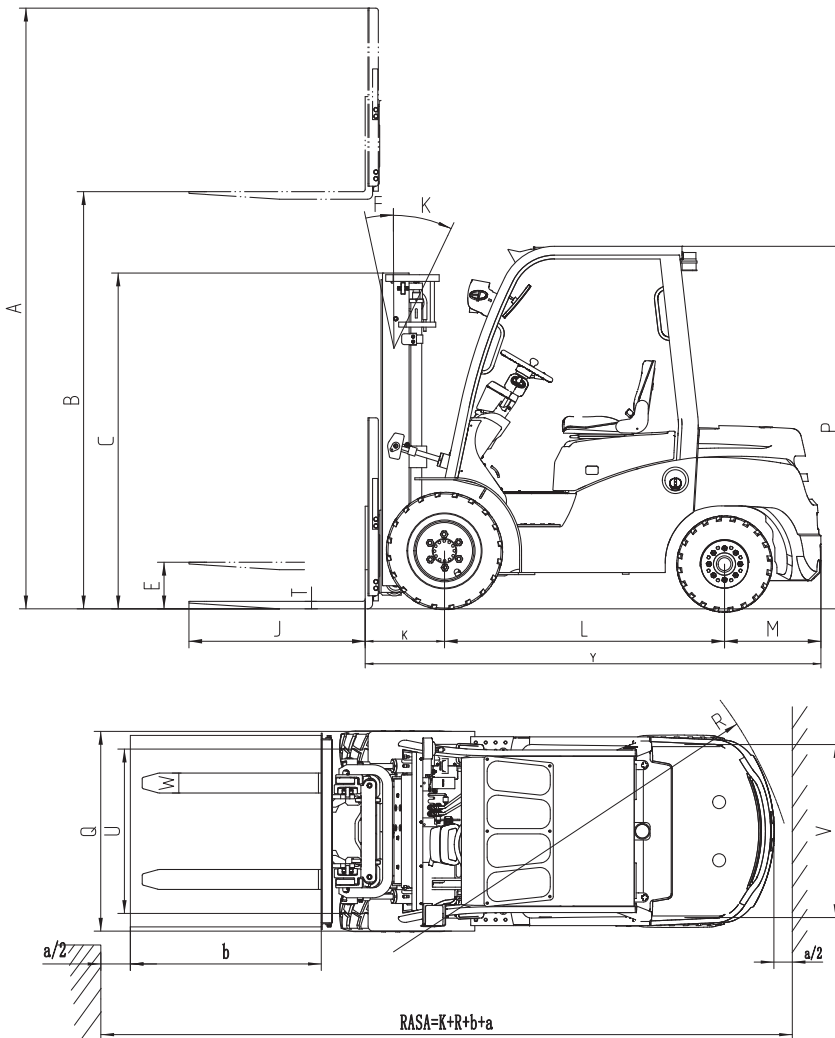

RATED CAPACITIES AND LOAD CENTERS GRAPH

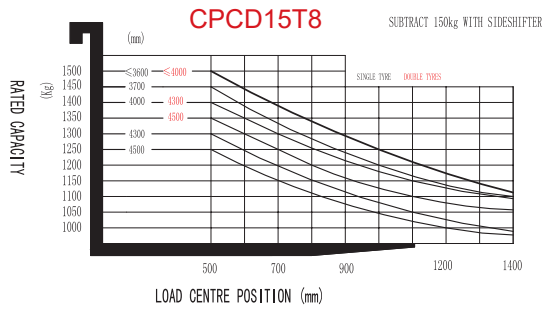

RATED CAPACITIES AND LOAD CENTERS GRAPH

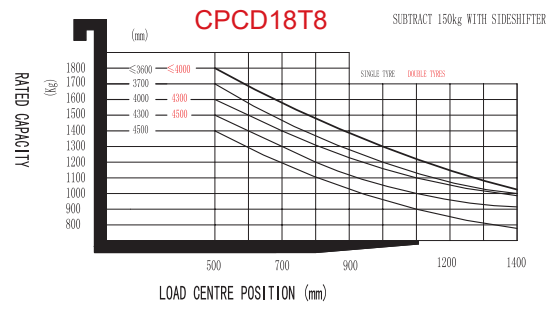

Option

Options		15/18T8
1	Fork length	○
2	Fork extension	○
3	Folded fork	○
4	Imported diesel engine	○
5	Import Gasoline Engine	○
6	LPG system	○
7	High exhaust	○
8	Dual air cleaners or special air cleaner	○
9	Solid rubber tire	○
10	No marking solid tire	○
11	Overhead guard	●
12	Mast options	○
13	Attachments	○
14	Integrated side shift	○
15	Cockpit	●
16	heater	○
17	Front windshield with wiper	○
18	Rear windshield with wiper	○
19	Fan	○
20	Full steel cabin room	○
21	LED front light	●
22	Rear working LED light	○
23	Fire extinguisher	○
24	Suspension seat	○
25	Seat switch	●
26	Warning light	●
27	Insulation mat	○
28	Double front tyre	○
29	OPS system	○

Note: ● standard ○ option — NA